

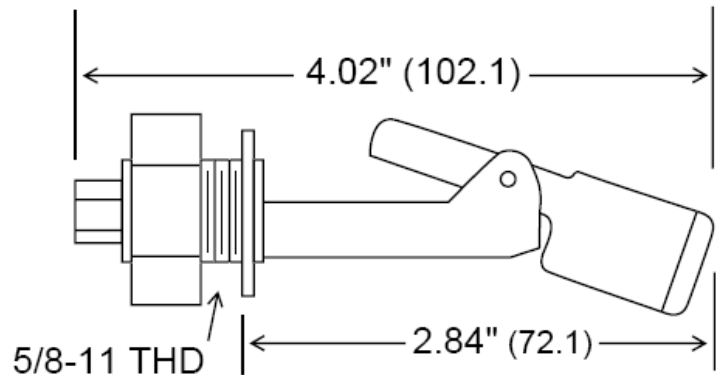

Horizontal Bulkhead Float Switch (FLT016)

- Versatile, economical and compact.
- Horizontal mount suitable for mounting through the side of a chamber
- UL Recognized part used in thousands of products.
- Normally closed; mount inverted for normally open operation.
- 5/8-11 threading; Includes a nut and sealing o-ring.
- Warranted against manufacturer defect for one year from delivery date.



Unit: Inches (mm)

Operation: When the float drops .50" from the horizontal position, the internal reed contacts separate and open a circuit. When the float rises to within .13" of the horizontal position, the contacts close and complete the circuit.

Materials:

Float: Polypropylene Foam
Stem: Polypropylene
Leads: 22 ga. MTW, 24", white
Top Fill: Epoxy

Specifications:*

Temperature: +105°C
Contact rating: 30VA
Max Pressure: 100 PSIG
Approvals: UL, CSA, NSF
Specific Gravity: .6

*Can be customized to your requirements